

Technical data sheet

Product features



Potato peeler 400-600 kg/h 20 kg

Model

SAP Code

00007934



- Material: Stainless steel
- Control type: Mechanical
- Maximal production per hour [kg/h]: 600
- Safety element: magnetic lid safety switch
- Start /stop: Yes
- Timer: Yes
- Transfer type: Strappy
- Water supply connection: 3/4"
- Drain valve diameter: 50
- Abrasive: Snadno odmínatelné brusné plochy a disk pro jednodušší čištění a výměnu
- Additional information: transparent plexiglass lid for checking all stages of processing

SAP Code	00007934	Power electric [kW]	1.150
Net Width [mm]	505	Loading	400 V / 3N - 50 Hz
Net Depth [mm]	737	Maximal production per hour [kg/h]	600
Net Height [mm]	1078	Weight capacity of the device container [kg]	20.00
Net Weight [kg]	60.00		

Technical data sheet

Technical drawing



Potato peeler 400-600 kg/h 20 kg

Model

SAP Code

00007934

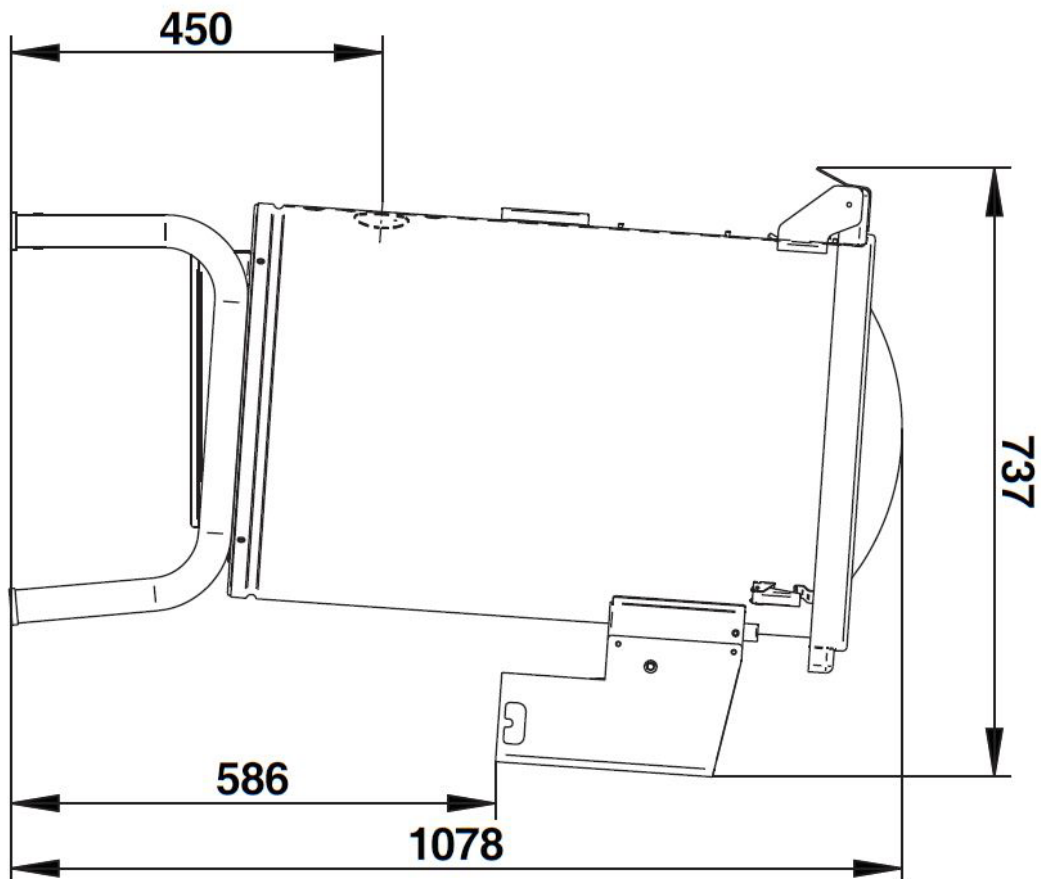
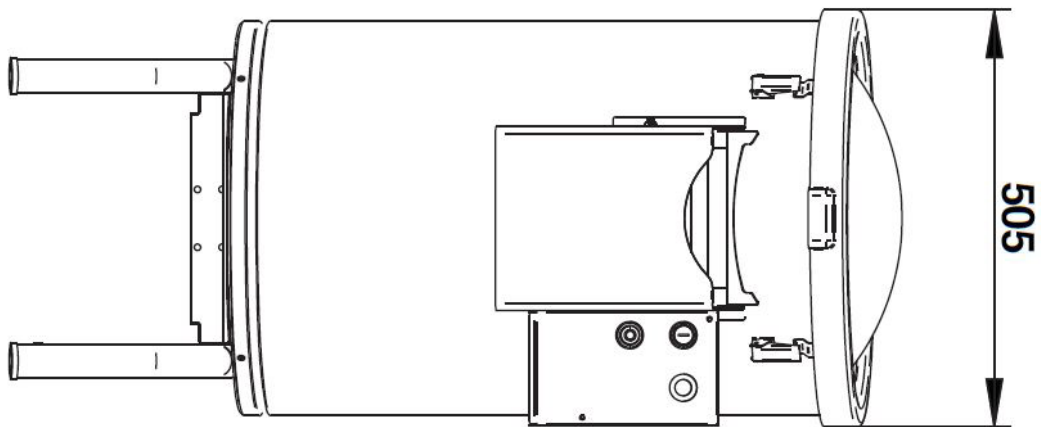

Technical data sheet

Product benefits



Potato peeler 400-600 kg/h 20 kg

Model

SAP Code

00007934

1

All-stainless steel construction

harmless to health for contact with food
robustness

- perfect sanitation
- long service life

2

Lid safety switch

safe operations

- protection of workers from injury caused by incorrect use

3

Transparent lid

visual inspection of all stages of processing

- product savings due to the possibility of checking the state of processing

Technical data sheet

Technical parameters



Potato peeler 400-600 kg/h 20 kg

Model

SAP Code

00007934

1. SAP Code:

00007934

2. Net Width [mm]:

505

3. Net Depth [mm]:

737

4. Net Height [mm]:

1078

5. Net Weight [kg]:

60.00

6. Gross Width [mm]:

700

7. Gross depth [mm]:

860

8. Gross Height [mm]:

1200

9. Gross Weight [kg]:

71.50

10. Device type:

Electric unit

11. Material:

Stainless steel

12. Power electric [kW]:

1.150

13. Loading:

400 V / 3N - 50 Hz

14. Control type:

Mechanical

15. Safety element:

magnetic lid safety switch

16. Start /stop:

Yes

17. Timer:

Yes

18. Transfer type:

Strappy

19. Maximal production per hour [kg/h]:

600

20. Additional information:

transparent plexiglass lid for checking all stages of processing

21. Water supply connection:

3/4"

22. Drain valve diameter:

50

23. Abrasive:

Snadno odnímatelné brusné plochy a disk pro jednodušší čištění a výměnu

24. Weight capacity of the device container [kg]:

20.00